

# GLYCOOMICS CLUSTERS OF LACTOSE AND ITS DERIVATIVES IN NANOTECHNOLOGY OF LIVING CULTURES

A. G. Khramtsov

North Caucasus Federal University,  
ul. Pushkina 1, Stavropol, 355009 Russia,  
e-mail: hramtsov@stv.runnet.ru

(Received April 24, 2014; Accepted in revised form August 3, 2014)

**Abstract:** A paradigm of scientific perspective on one of the main components of raw milk - lactose (milk sugar) in terms of emerging views about milk science - LACTOOMICS with the logistic term GLYCOOMICS as a separate section on lactose and its derivatives is stated. The role of lactose and its derivatives in the biocenosis of living cultures is shown. The contribution of Nobel Prize winners in the development of the issues related to lactose as the "life sugar" is estimated. Optimized molecular lactose anomer structures and calculations of electrostatic potential are presented. The possibility of lactose derivatives synthesis with the use of molecular-kinetic patterns and neural network simulation is proved. These provisions allow us to establish a system of scientific views on one of the main components of raw milk at the level of post-genomic representations.

**Keywords:** Lactoomics, glycoomics, lactose (milk sugar), lactose derivatives, lactulose, molecular structures, neural network simulation.

UDC 637.044+637.345  
DOI 10.12737/11168

## INTRODUCTION

On the assumptions of the declared LACTOOMICS postulates as the science of MILK [1] and the principles of dairy logistics [2] it seems appropriate to outline in a brief form some considerations in terms of innovation and information technology relating to one of the major components of milk – lactose (milk sugar) – an ideal nanocluster of the "dwarf" size – 1 nanometer. If whey can be considered a "universal agricultural raw material" (by Academician N. Lipatov), lactose (more than 70% of dry matter) should be referred to as an idealized model for the food nanotechnology of "Living Cultures". In this case, it is clear, especially in recent time that alongside with lactose its derivatives should be considered as natural products of directed and controlled modification. In summary, it seems quite logical to have an independent scientific section of LACTOOMICS - GLYCOOMICS designated by the article title. Certainly, along with GLYCOOMICS, it seems logical to establish LIPIDOMICS (milk fat) and PROTEOMICS (milk proteins - casein and whey).

## OBJECT AND METHODS OF STUDY

The term GLYCOOMICS was formed on the basis of the published materials [3, 4] to the depth of more than 400 years (from the time of Fabrizio Bertholletti) and systematized in the collections of the Symposium of the International Dairy Federation (Russia, Moscow, May, 2007). They are also found in specialized monographs [5, 6] and the materials of the fifth (Paris, 2008), and the sixth (USA, 2011) International Conferences, devoted entirely to the primary lactose

(milk) raw material – whey. Conference proceedings are published and in a systematic form (English and Russian versions) are available from the author.

From a genetic point of view, according to the theory of adequate nutrition and trophic ecology, lactose should be considered as LIFE SUGAR – naturally given component of the secretion (milk) of mammals and humans. It, like all carbohydrates, stands at the beginning and the end of the renewable energy and entropy flows passing through the biosphere.

It should be noted that lactose and its derivatives were in one way or another the object (subject) of the studies of prominent scientists honored with the highest award of the Earth civilization – Nobel Prize. As an exclusive example given below is a list of Nobel Prize winners (by year of awarding), whose works, in our opinion, are more or less relevant to the objects of the MMF Symposium.

*E. Fischer* (1902) studied carbohydrates, including lactose. He owns a brilliant solution to the problem of the synthesis of natural sugars and other compounds.

*I. Pavlov* (1904), studying the function of the digestive glands, found that the most useful and easily digestible for the body of mammals are the components of dairy products. Pavlov believed milk and its components to be amazing food prepared by nature due to all these advantages.

*I. Mechnikov* together with *P. Ehrlich* (1908) investigated the questions of immunity and health. In his book "Sketches of optimism" ("Life Extension"), *I. Mechnikov* examines the lactotherapy phenomenon as prevention of diseases and life extension, thanks to eating dairy products containing lactose and lactics.

A. Fleming, E. Chain, H. Flory (1945) who discovered penicillin and its curative effect in various infectious diseases, considered lactose to be a major component of nutrient medium used for the synthesis of antibiotics.

L. Pauling (1954) investigated the nature of chemical bond and its application to determine the structure of compounds. He is widely known for his work on orthomolecular medicine, elimination of lactose intolerance, as well as the development of the concept of dietary supplements.

F. Jacob, J. Monod, A. Lvov (1965) developed the theory of genetic control of enzyme synthesis on the example of the lactose operon (lac-operon) of *Escherichia coli* bacterium.

It is quite possible that the day when the next Nobel Prize will be awarded for the research related to this unique LIFE SUGAR is not far off then.

## RESULTS AND DISCUSSION

The ancient Greeks, peering into the infinity of the sky, found an analogy on Earth – MILK, thus "Milky Way" and GALAXY were born. Our fellowmen A. Bochkov, V. Afanasiev, G. Zaykov [7], while considering the

problem of carbohydrates in the Earth's biosphere, also associated the names hierarchy of e.g. milk glycals with the Universe: lactose (galactose) – Milky Way – GALAXY. What kind of an interesting, imaginative and important comparison for dairy science it is!

Aristotle in his extant treatise "On the Origin of Animals" already pointed out that milk "contains fire, i.e. the warmth of the body." Apparently as a fuel of this warmth we can assume with great certainty the presence of lactose in dairy raw materials, which is the first among the other components (fat and protein) to be subjected to bioenergy conversion. When comparing, lactose ability to "burn" (to be fermented) in a body is referred to as "oak wood" (monosaccharides "burn as stubble", sucrose as "birch wood"). Our "favorite" then – the promoter of bifidobacteria and prebiotic - lactulose, provides "fuel" for finishing sections of gastrointestinal tract (GIT) of the body, "burning" possible troubles. Figuratively speaking, lactose is the main "repository" of raw milk energy with the ratio of glucose: adenosine triphosphate (ATP) at the level of 35 : 1. The diagram below (Fig. 1) shows the uses of milk sugar (lactose). They are quite numerous and constantly expanding.

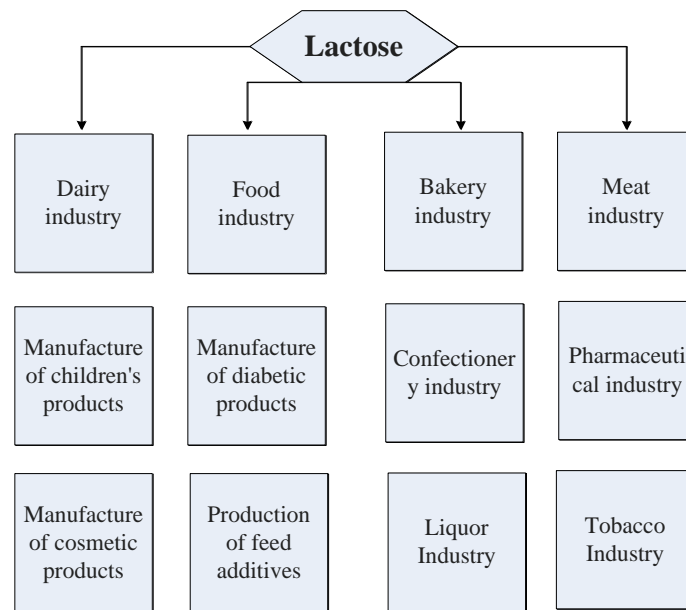

**Fig. 1.** Schematic diagram of some directions of milk sugar (lactose) usage.

Biological synthesis of lactose in the alveolus of female mammals is the subject of research by our colleagues – biologists and breeders. It is definitely identified that the health and the lactose content of lactating females are interrelated and can be used in genomics as a certain "life affirmation" test [8].

Chemical synthesis of lactose is still lying in the portfolio of possible innovative breakthroughs of the twenty-first century and is awaiting for its researchers. Therefore, the only source of the life sugar can only be some dairy, lactose bearing raw material. This is the heritage and a kind of industry reserve, which is yet to be evaluated by people.

Lactose in the life cycle of body metabolism is considered not only to perform energetic, but also

plastic, immune, and some other not yet identified functions. For example, the founder of medicine Avicenna believed that "milk sugar" of the nurse forms the "thin" (now smutent) lining of the brain of infants which effects lipotropically on the choline. There had long been known "sweet powder", which was prepared by nomads from mare whey. It was applied as a "magic remedy" for "feeding" children, the weak and the sick; giving them "life force" and health (immunity). According to the figurative expression of the outstanding twentieth century physiologist and Nobel Prize winner, Academician I. Pavlov, lactose should be considered as one of the three main components of the "amazing food prepared by nature itself." Lactose monosaccharide components also play an important

physiological role in the body, especially that of the newborn: glucose provides synthesis of reserve carbohydrate - GLYCOGEN (energy "safe" of a body), and galactose - brain GANGLIOSIDES.

Lactose intolerance in some representatives of the human race at the genetic level is still not fully decoded. Although it should be noted that at the MMF Symposium (Russia, Moscow, 2007), "the mystery of the veil" was ajar in numerous reports [3].

In everyday practice, Thilo Shleyp's slang - "Caution: lactose!" is apparently legitimate [9]. Milk sugar extraction in the so-called lactose-free products is still another significant source of lactose and its derivatives in future [10]. This is a separate, independent problem for researchers and practitioners.

Lactose ( $C_{12}H_{22}O_{11}$ ) composition, properties, biocenosis and its solutions are well studied and published in the open literature [5, 6]. Recently its anomeric conformation has been identified, calculations of torsion angles and valence bonds for the prediction of chemical stability in terms of the synthesis of derivatives have been made. At the same

time, the sphere of activity of physicists, chemists, biologists and engineers in this field is infinite - from the puzzle about the ratio of anomeric forms, such as in cow and human milk, to anomalies of solubility, crystallization and information capacity. Figure 2 shows the optimized structural formula of lactose alpha-isomer, which is extracted from lactose bearing raw material (mainly whey from cheese production - so-called cheese whey).

The results of calculation of molecular electrostatic potential distribution in two dimensions are shown in Fig. 3. The calculation of molecular electrostatic potential spatial distribution is shown in Fig. 4.

These patterns clearly show the areas of increased electron density, which may be first attacked by the electrophilic reagent, as well as the areas with minimum electron density, which can be attacked by nucleophilic reagents. The localization of domains with deficient electron density may serve to explain the direction of the attack of nucleophiles with the subsequent formation of oxynitrils, oxymes, hydrazones, endiols and other chemical derivatives.

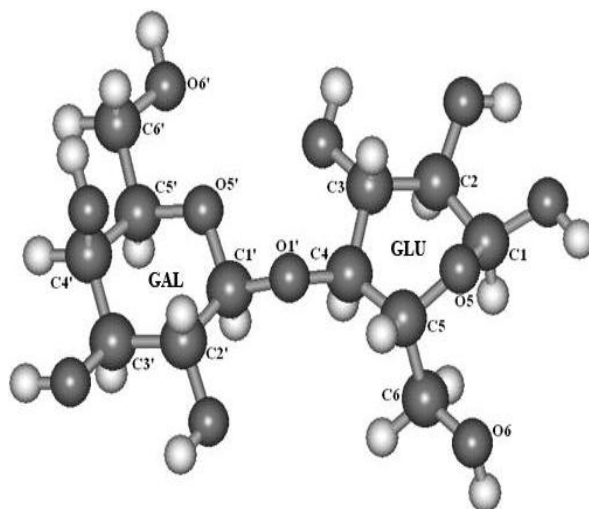

Fig. 2. The structure of  $\alpha$ -lactose molecule (GAL, GLU).

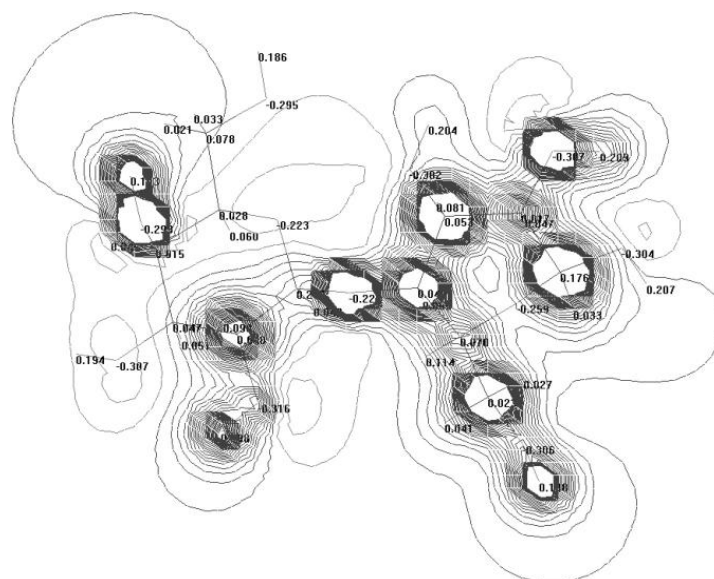
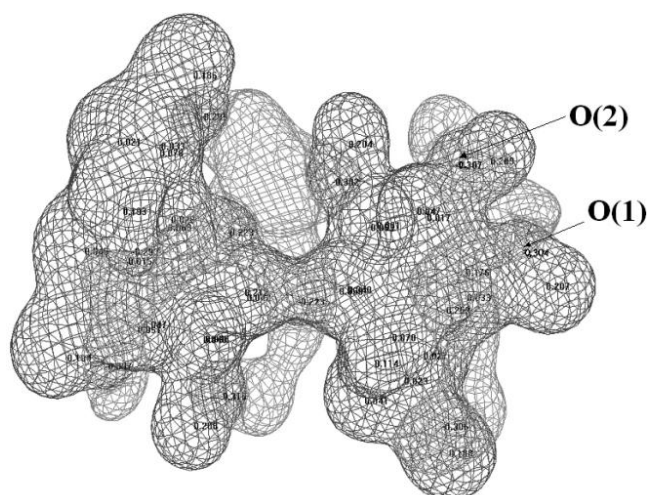
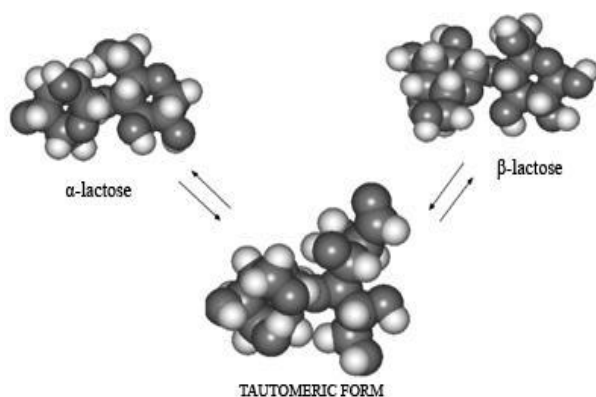

Fig. 3.  $\alpha$ -D-lactose molecule. The distribution pattern of molecular electrostatic potential in semi-empirical calculation.



**Fig. 4.**  $\alpha$ -D-lactose molecule. The spatial distribution pattern of molecular electrostatic potential.

Lactose polymorphism and uniqueness are to some extent confirmed by molecular structure of this natural carbohydrate, shown in Fig. 5.



**Fig. 5.** The process of lactose mutarotation in aqueous solution.

Table 1 shows the main properties of geometrically optimized molecular structures of lactose anomers which were defined by quantum mechanics techniques. It should be noted that the heat of formation  $\Delta H_{298}$  coincides with the known data, the dipole shows the uniformity of electron density distribution, and RMS gradient is close to zero.

**Table 1.** Molecular properties of  $\alpha$ - and  $\beta$ -lactose

Name	The heat of formation, kcal / mol	Dipole moment, Debye	RMS gradient kcal/ ( $\text{\AA} \times \text{mol}$ )
$\alpha$ - lactose	-522.462	1.277	0.099950
$\beta$ - lactose	-523.046	1.711	0.070530

Lactose resources in milk produced on the planet (more than 600 million tons per year) make up to about 27 million (those of sucrose are at the level of 100 million tons). Lactose bearing raw material (whey - more than 100 million tons per year) contains approximately 4.5 million tons of lactose - a potential raw material for the production of milk sugar. Using methodical approach of the company Fresenius Kabi,

we have such fragmented information in terms of milk sugar production - at the level of 700 thousand tons per year; derivatives - 100 thousand tons per year, including lactulose - 50 thousand tons per year. Analyzing the number of figures (millions of tons): 600-100 - 27/4.5/0.7-0.1-0.05 we can confidently assert the possibilities of lactose (milk sugar) and its derivatives production to be practically unlimited. They may be of interest from the standpoint of global macroeconomics and dairy industry micromarketing, according to the president of MMF *Mr. D. Begg* [11].

Lactose removing from lactose bearing raw material is not now a secret (it was hidden in the period of the organization of antibiotics production). There is a worldwide large-scale commercial production but unfortunately, there has not even been a common technology yet. Figure 6 shows operator model for producing high-quality (refined, official) milk sugar, adopted in the world nowadays.

The degree of lactose extraction does not exceed 70%. Intensive technology of spray drying method requires industrial implementation. Molecular sieve filtration and biotransformation await for their researchers, particularly in terms of practice. The portfolio of innovations has lactosats studied at the school of the professor *Y. Zaikovskiy* [12] (Omsk AI, 40-s of the twentieth century), then a doctoral thesis of *M. Kovalenko* [13] (LTIHP, 60-s of the twentieth century). A separate theme is a full and efficient use of secondary (casein powder, cream cheese, whey proteins) and intermediate (condensate, molasses, "cake" from a filter press, mineralization substance) products. It should be emphasized that lactose production on the principles of non-waste technology helps to solve the environmental problems of complete cycle of raw milk industrial processing.

Lactose derivatives have always taken place in the technologies of living cultures (gastrointestinal tract - GIT) and fermented (lactic) products - beverages, cheese, cottage cheese, sour cream. They can be synthesized in the required direction and controlled from lactose. Figure 7 shows a diagram of possible directions of lactose derivatives synthesis. The approximate range of currently known lactose derivatives exceeds more than 50 names and is constantly updating.

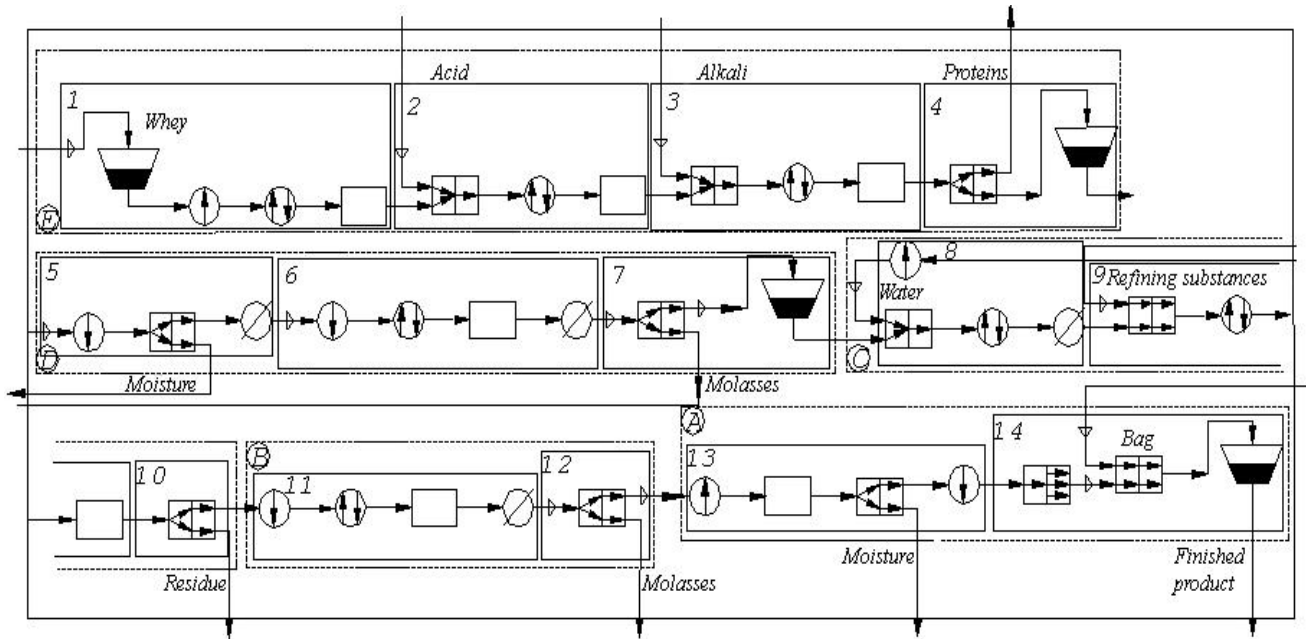

Symbols of milk sugar production processes:

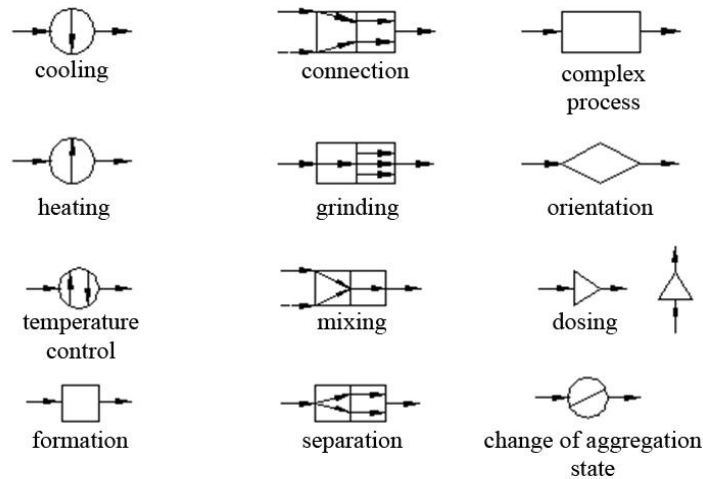

**Fig. 6.** Operator model of high-quality milk sugar production technology:

Designation of subsystems: (A) Finished product formation with desired physical, chemical and organoleptic characteristics; (B) Obtaining of wet crystals of a predetermined composition; (C) Obtaining of purified milk sugar solution of a given composition; (D) Obtaining of wet lactose crystals of a given composition; (E) Obtaining of purified whey of a given composition. Designation of operators: (1) Thermal denaturation of protein whey; (2) Thermal denaturation of whey proteins with acidification; (3) Thermal denaturation of whey proteins with deoxidation; (4) Discharge of precipitated whey proteins; (5) Concentration of purified whey; (6) Lactose crystallization in condensed whey; (7) Discharge of wet crystals; (8) Dissolution of wet crystals; (9) Refining of lactose solution; (10) Separation of refining substances; (11) Crystallization of purified lactose solution; (12) Discharge of wet crystals; (13) Drying of wet crystals; (14) Packing and packaging of a finished product.

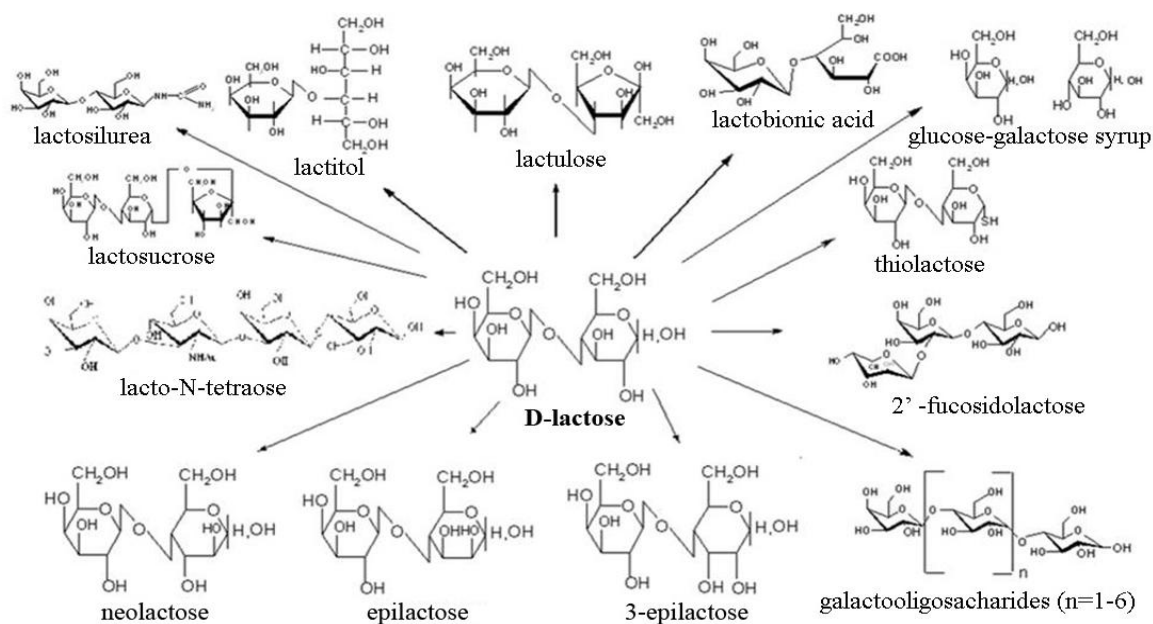

**Fig. 7.** Diagram of genetic relationship between lactose and its derivatives.

Lactulose, galactose and glucose syrup are worldwide known derivatives, as it was pointed out above. Lactitol, lactosucrose, galactooligosaccharides and some other derivatives are still little known even to professionals. Iodine-, sulfur-, and selen- derivatives are ready to come to life, noteworthy is the synthesis of ethanol and laktosilurea.

Lactose selectins - bacteriocines, fucose, tagatose and lactobionic acid are already in demand in the world market. It is assumed wherein that the economic potential of lactose derivatives not only pays for the cost of their creation, but also offsets all the costs of starting feedstock. Some of them, such as lactulose are necessary for the suffering.

The revival of such derivatives as oligosaccharides [14] started from the middle of the twentieth century, especially with regard to LACTULOSE, the latter being advisable to linger for consideration separately.

So what kind of "milk miracle" is lactulose, synthesis of which was awarded the prize of the Russian Federation Government in the field of science and technology?

The life cycle of lactulose began in the mid-twentieth century, and has a tendency to expand. An international body for its use – ILAG was established, which is a credit to the organizers and creates real perspectives - a precedent for other lactose derivatives. Lactulose molecular structure is shown in Fig. 8.

Similarly to lactose anomers the main properties of molecular structure of lactulose in an optimized

geometric shape were defined by quantum mechanics techniques and are listed below: the heat of formation, kcal / mol 478.626; Dipole moment, Debye 1.981; RMS gradient kcal / (Å mol x) 0.004132.

The data and figures in Table 1 indicate the correctness of geometric optimization with the minimization of potential energy, energy balance of properties of the culture and the possibility of directed effect upon the molecules of aldose and ketosis.

Mechanism of reagent and nonchemical transformation of lactose (aldose) into lactulose (ketosis) is studied in detail [15] – bio-cluster nanotechnology on the proton level is assessed in terms of the energy activation on the Arrhenius formula and described by multiplicity perceptron with the help of "neural networks" methodology (Figs. 9-11).

In virtual experiments there was the degree of isomerization of 95% achieved. In future, biotransformation and directional heat-electro-physical effect on lactose molecule, e.g. by a laser beam in lactose solutions and dairy raw materials are possible.

Dozens of original (know-how) production methods of lactulose concentrates in liquid and dry forms - "Normase", "Dufalac", "Lactusan", "Alkosoft", "Lazet", "Lael" and others are worldwide known. Figure 12 shows the currently accepted technological scheme (operator model) of lactulose concentrate production.

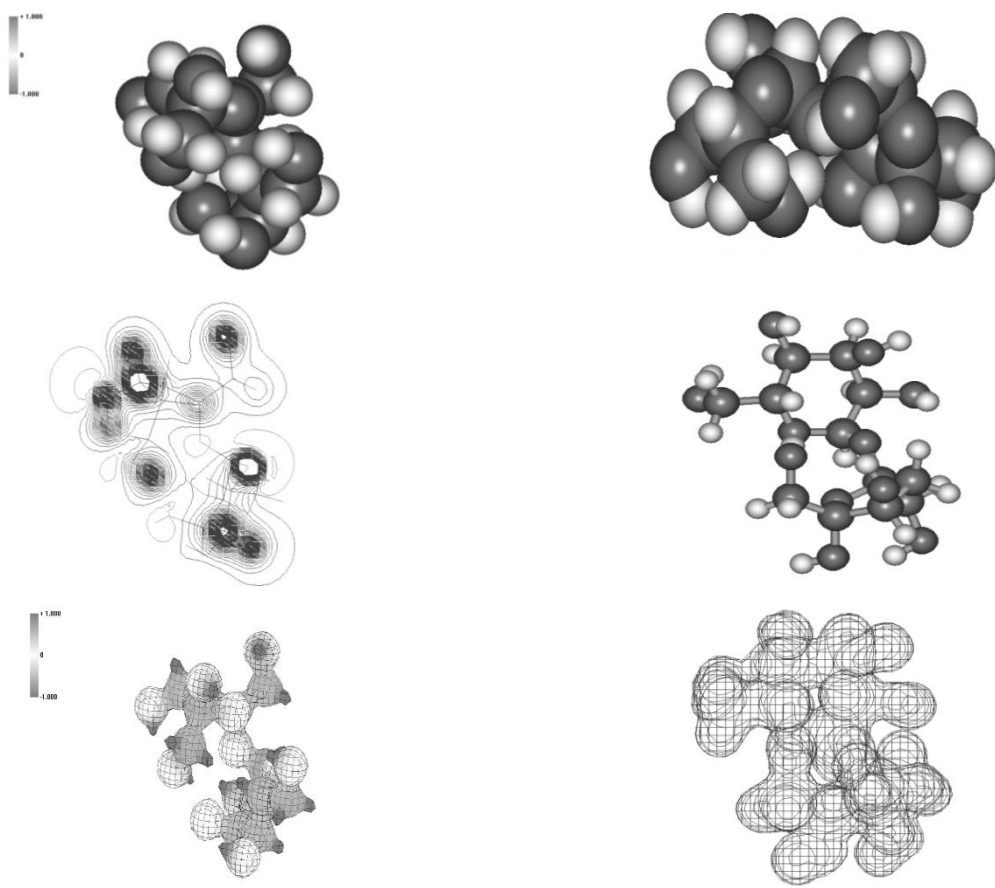

Fig. 8. Lactulose molecular structure.

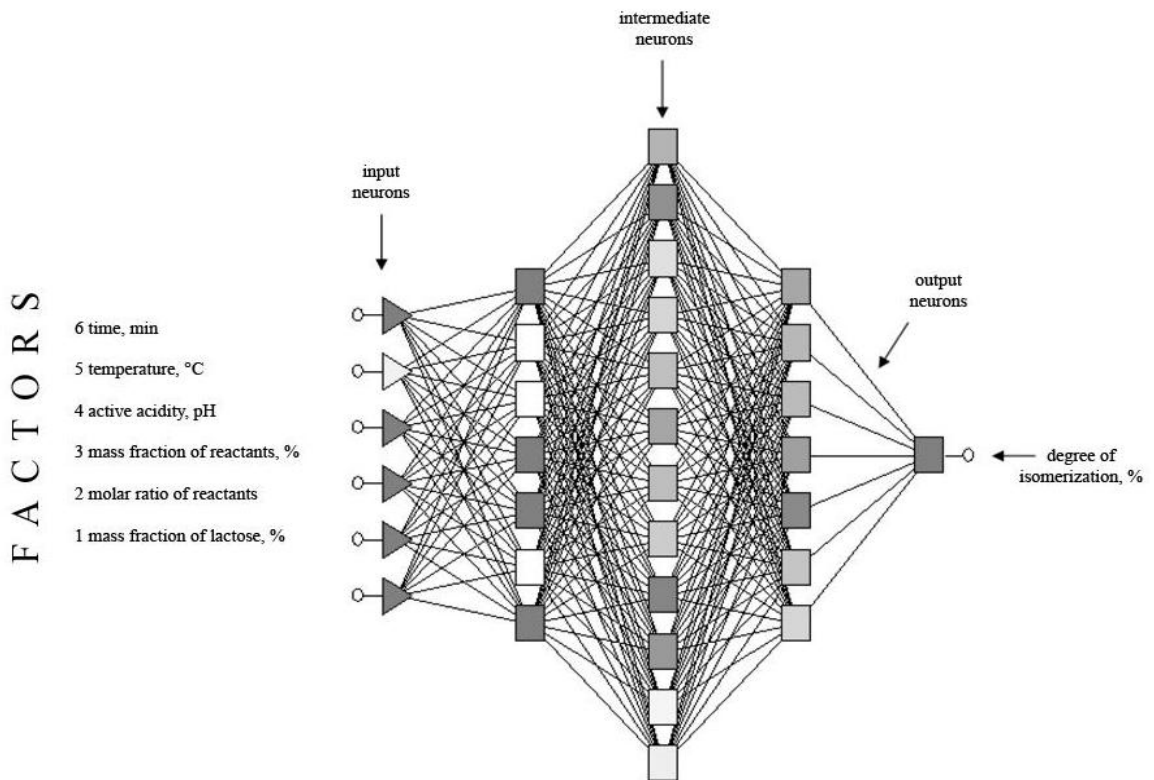
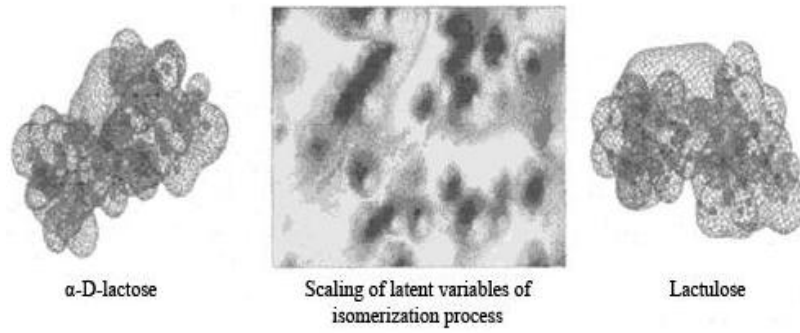
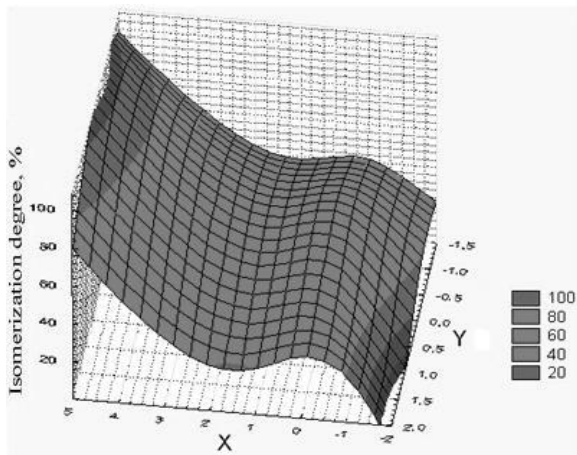

Fig. 9. Multiplicity perceptron of scaling lactose into lactulose.



**Fig. 10.** Conversion of lactose into lactulose with slice scaling techniques of neural networks.



(a)

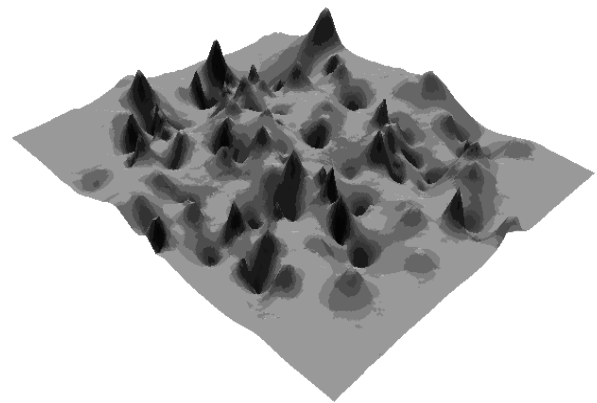

(b)

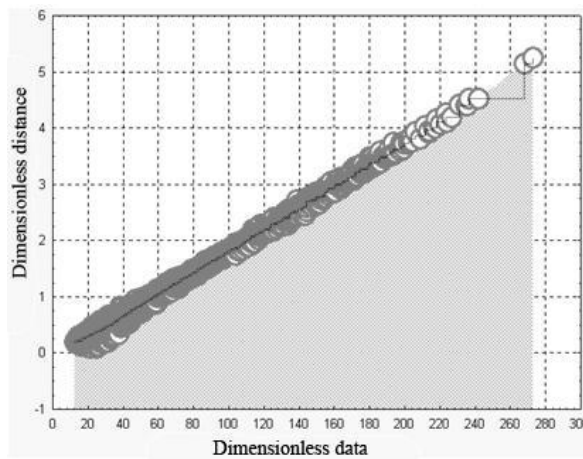

(c)

**Fig. 11.** (a) The response functions, (b) the efficiency of neural network approximation and (c) Shepard scheme of isomerization conversion of lactose into lactulose.



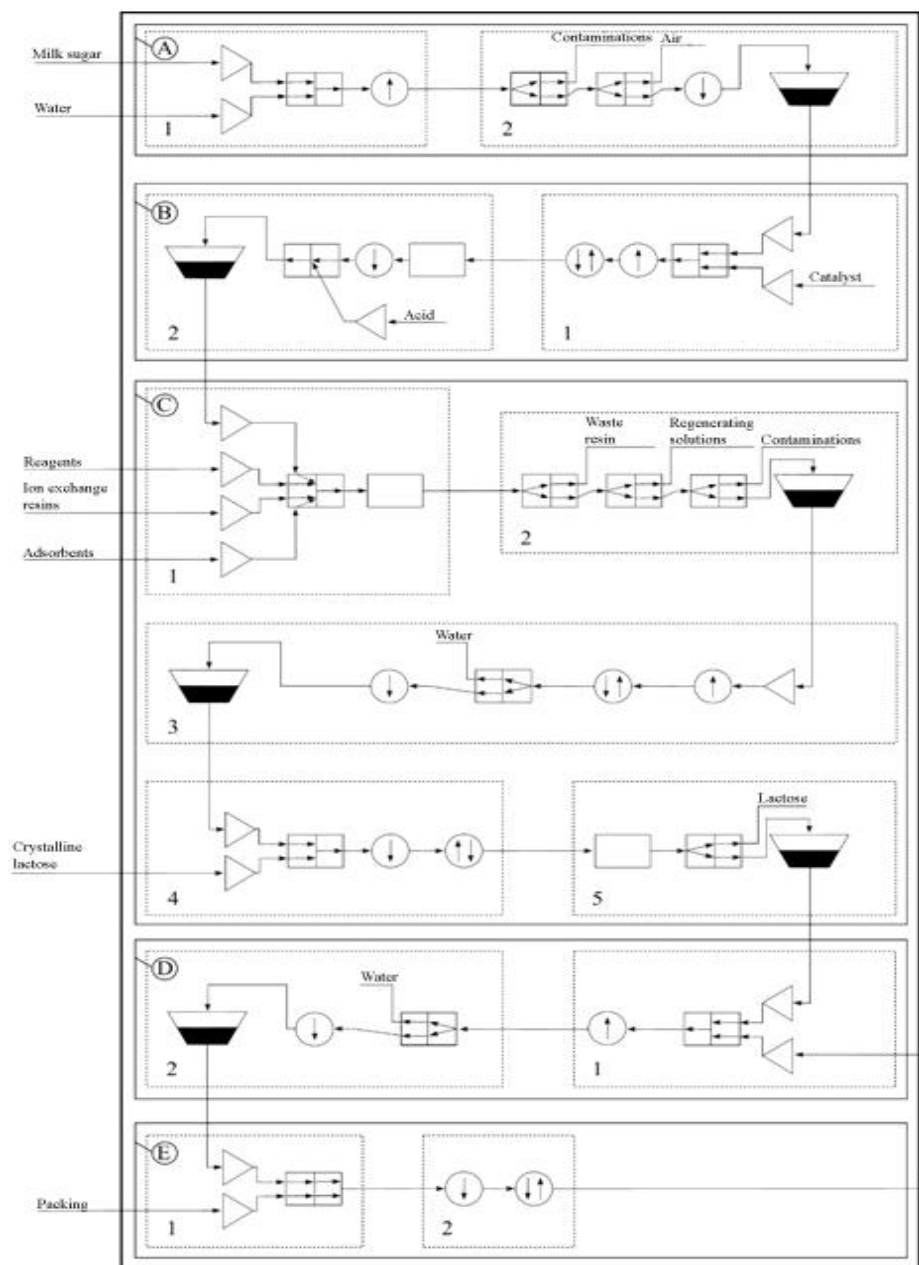

**Fig. 12.** An operator model of "Lactulose production technology": (A) subsystem of preparation of raw materials, which has operators: 1 – dilution, 2 – cleaning; (B) subsystem of lactose into lactulose isomerization which has operators: 1 – making catalysts, 2 – temperature control and neutralization; (C) subsystem of lactulose selection from reaction mixture which has operators: 1 – introducing reagents and exposure, 2 – departments of reagents and purification (separation of waste reagents), 3 – thickening, 4 – crystallization of lactose, 5 – discharge of crystallized lactose; (D) subsystem of lactulose solution drying which has the operators: 1 – addition of fillers, 2 – drying and cooling; (E) subsystem of finished product packing and cooling, which has operators: 1 – packing, 2 – cooling and intermediate storage.

As it was mentioned above, problems and prospects for other lactose derivatives obtaining are still to be solved in scientific research, and especially in practice.

The application of lactose and its derivatives is a separate, independent and rather large-scale topic for researchers and practitioners in various industries. It has just been marked in the form of a list and some samples of products. The calling card of lactose and therefore that of our dairy industry is on the shelves of nearly any pharmacy. That is the preparation of a vast array of medicines. Promising is lactitol and

lactosucrose obtaining as an alternative to "white death" – sucrose. Lactulose may be considered as similar to a cigarette filter as a "safe threshold" of existing evils of mankind - alcohol.

Bioinformatic tablets based on the lactose or lactulose lattice, in principle, can change our perception of medicine. An anomer crystal biochip of lactose, in the apt words of the professional, can accommodate the entire Library of Congress. Finally, as a renewable byproduct resource of natural raw materials, lactose may be considered as an alternative to disappearing energy.

In general, you can imagine vividly illuminated the place and the role of lactose in the biosphere of our planet in the following algorithm:

- **Lactose around us** in lactose bearing raw materials and dairy products;
- **Lactose within us** in the form of the carbohydrate part of our diet and metabolism;
- **Lactose for us** in the form of milk sugar and its derivatives.

It should be noted that lactose is one of the most important and necessary components of functional foods (FF):

- Probiotics - nutrient medium for microorganisms;
- Prebiotics - starting raw material for synthesis;
- Synbiotics - a combination of pre- and probiotics in fermented dairy products of a new generation.

Certainly, the total consumption of lactose and its derivatives, especially lactulose, should not exceed the recommended standards similar to, for example, table salt.

All the information mentioned above is advisory by nature, as a possible motivation for the activity of researchers and practitioners within possible scientific section of milk science – LACTOOMICS in the rank of specific and separate section GLICOOMICS.

## CONCLUSIONS

Assessing the place of lactose and its derivatives in the biosphere of our planet – Earth on the whole, the following factors can be systematically noted.

Utilization of the resulting lactose (milk sugar) in the annually produced milk in the world can be systematized in the following seven areas.

1. Rearing of newborn mammals (babies).
2. Production (obtaining) of dairy products.
3. Utilization of dairy products in human nutrition.
4. Production of fodder for livestock and poultry.
5. Utilization of fodder for livestock and poultry.
6. Production and use of milk sugar (lactose).
7. Obtaining and use of milk sugar derivatives (lactose).

Three (2, 6, 7) of the seven areas have in principle, a direct relation to the dairy industry, directly related is one more (4) and mediated are the other three (1 – substitutes, 3 - trade, 5 - utility livestock farms). Thus, the industry and its staffing should be focused on the whole range of possible uses of lactose dairy raw materials, which is especially important in a globalized world market, and for Russians – entry to WTO.

*To the blessed memory of my unforgettable teacher,  
professor Mihail Sergeevich Kovalenko,  
(1906–1979)*

## REFERENCES

1. Khramtsov, A.G., Laktoomika – nauka o moloke. Modernizacija nashih predstavlenij (Lactoomics - science about milk. Upgrading of our notions), *Molochnaja promyshlennost' (Dairy industry)*, 2011, no. 6, pp.45-48.
2. Khramtsov, A.G., Logistika molochnogo dela. Prognosticheskiy vzglyad (Logistics of dairy systems. The way forward), *Pererabotka moloka (Milk Processing)*, 2011, no. 6, pp. 48-50.
3. *Tezisy Mezhdunarodnogo simpoziuma MMF «Laktoza i ee proizvodnye» (Moskva, 14-16 maja 2007) i regional'noj konferencii MMF «Kislomolochnye produkty – tehnologii i pitanie» (Moskva, 17 maja 2007)* (Proceedings of the International MMF Symposium "Lactose and its derivatives" (Moscow, 14-16 May, 2007) and the MMF Regional Conference "Dairy products - technology and power" (Moscow, May 17, 2007)). Moscow, ERDC "Educational Research and Development Center of the dairy industry", 2007. 402 p.
4. *International Dairy Federation Symposium "Lactose and its derivatives"*, Moscow, 14-16 may, 2007. 128 p.
5. Sinel'nikov, B.M., Khramtsov, A.G., Evdokimov, I.A., Rjabceva, S.A., and Serov, A.V., *Laktoza i ee proizvodnye (Lactose and its derivatives)*, St. Petersburg: "Professija" Publ., 2007. 770 p.
6. Khramtsov, A.G., *Fenomen molochnoy syvorotki (Whey phenomenon)*, St. Petersburg: "Professija" Publ., 2011. 804 p.
7. Bochkov, A.F., Bochkov, A.F., Afanas'ev, V.A., and Zajkov, G.E., *Uglevody (Carbohydrates)*. Moscow: Nauka Publ., 1980. 176 p.
8. Pokrovskij, A. A., Rol' molochnyh produktov v pitanii naselenija (The role of dairy products in people's nutrition), *Molochnaja promyshlennost' (Dairy Industry)*, 1969, no. 9, pp.12-14.
9. Shleyp Tilo, *Ostorozhno – laktoza! Kogda molochnyi sakhar ne sovmestim so zdorov'em (Caution - lactose! When lactose is not compatible with health)*, St. Petersburg: IG "Ves" Publ., 2004. 96 p.
10. Shuvaev, V.A., and Kunizhev, S.M., *Novye tehnologii v proizvodstve molochnyh produktov (New technologies in dairy production)*, Moscow: DeLee print, 2004. 203 p.
11. Begg, D., Innovacionnye tehnologii ili sohranenie vekovyh tradicij. Kto pobedit? (Innovative technologies or preservation of centuries-old traditions. Who will win?), *Molochnaja promyshlennost' (Dairy Industry)*, 2006, no. 4, pp.42-46.
12. Zajkovskij, Ja.S., *Himija i fizika moloka i molochnyh produktov (Chemistry and physics of milk and dairy products)*, Moscow: Pishhepromizdat, 1950, 280 p.
13. Kovalenko, M.S., *Nauchno-tehnicheskie osnovy tehnologicheskikh processov poluchenija  $\alpha$  i  $\beta$ -form molochnogo sahara iz syvorotki. Avtoref. diss. dokt. tekhn. nauk (Scientific and technical basis of technological processes of  $\alpha$  and  $\beta$ -forms of lactose from whey. Dr. tech. sci. autoabstract diss.)*. Leningrad, 1954. 52 p.
14. Modler, H.W., Berlouez, I., Holland, S., et al., Oligosaccharides and probiotic bacteria, *Bull. of the IDF*, 1996, no. 313, p. 58.
15. Rjabceva, S.A., *Tehnologija laktulozy (Lactulose Technology)*, Moscow: DeLee print, 2003. 232 p.

