

MIXTURES FOR VERTEBROPLASTY: THE FLOWABILITY OF THEIR COMPONENTS AND A NEW PRODUCTION TECHNOLOGY USING A CENTRIFUGAL MIXER

D. M. Borodulin* and D. V. Sukhorukov

Kemerovo Institute of Food Science and Technology,
bul'v. Stroitelei 47, Kemerovo, 650056 Russia,
*phone: 8-950-272-59-94, e-mail: Pioner_dias@mail.ru

(Received March 7, 2014; accepted in revised form March 17, 2014)

Abstract: The article deals with the production of bone cement, which is used in various fields of medicine. A new technology for producing medical cement mixtures is presented. Particular attention is paid to use of bone cement in the treatment of vertebral compression fractures associated with osteoporosis. The incidence rate of osteoporosis and its clinical manifestations is expected to increase four times in the next half-century due to the growth of population and the increase in life expectancy. Problems of contemporary medicine that are associated with obtaining granular mixtures of preset quality and composition are discussed. Information about the flowability of the components of cement mixtures is presented. The concept of a criterion of flowability is introduced for the first time for rationally choosing a mixing method according to the flowability of the components for preparing quality cement mixtures. Flowability data for cement mixture components have been obtained to optimize the mixing process. A dimensionless equation is set up to calculate the power requirement for the mixing process. The quality of the resulting granular compositions depends primarily on the physicomachanical properties of the materials being mixed. A continuous, centrifugal, bone cement mixing unit is described, and the principle of its operation is considered. The performance of continuous mixers has been evaluated in terms of output capacity, specific energy consumption, and heterogeneity coefficient. The new, centrifugal mixer has been demonstrated to be more efficient in bone cement production than the pulsating mixer.

Keywords: vertebroplasty, centrifugal mixer, pulsating mixer, bone cement, polymethyl methacrylate, flowability, hydroxylapatite ceramic, tricalcium phosphate ceramic

UDC 621.929.2/9
DOI 10.12737/4137

INTRODUCTION

The problem of treating osteoporosis is a challenge for present-day health care, for this disease has become quite widespread among the elderly. Approximately 40% of the women and 13% of the men older than 50 years have had one bone fracture or more [8, 10].

It is predicted that the incidence rate of osteoporosis and its clinical manifestations, such as femoral neck fracture, will have increased four times within the next half-century because of the growth of population and the increasing life expectancy [5, 10].

Conventional methods of curing compression fractures of vertebral bodies involve use of analgesics and muscle relaxants, immobilization, bed rest, physiotherapy, and wearing a body jacket [2, 9].

These methods suffer from the following drawbacks: lengthy confinement to bed and the impossibility of early mobilization because of the marked pain syndrome lead to lack of appetite, to impaired glucose tolerance, and to development of hypostatic pneumonia, phlebotrombosis, and, as a consequence, pulmonary artery thromboembolism. In addition, the hypodynamia implied by the bed rest regime diminishes the density of bone tissue (by up to 2% per week), thus causing progress of osteoporosis [6, 7]. For this reason,

vertebroplasty is being increasingly used in the symptomatic treatment of pathological compression fractures associated with osteoporosis and osteopenia.

The results of clinical application of vertebroplasty, analyzed by many authors, demonstrated the high effectiveness of this technique in restoring the supporting ability of vertebral column segments affected by tumor-induced osteolysis. This method is primarily indicated for those oncological patients who cannot be subjected to radical surgery for some reason.

Application of vertebroplasty to patients with metastatic spinal injuries would shorten the bed rest period, extend the patient mobilization period, prevent the progress of the pain syndrome, and reduce the risk of neurological complications. Vertebroplasty, a minimally invasive procedure, would make it possible to shorten the hospital stay time. In combination with less frequent use of analgesics, it would reduce the cost of the hospital treatment of this category of patients.

Vertebroplasty is widely used abroad in the treatment of pain syndrome and pathological fractures that are due to metastatic injuries of the vertebral column and osteoporosis. The largest number of vertebroplastic manipulations in the world have been carried out in the United States and Western Europe;

among the countries of the Commonwealth of Independent States, the leaders in this field are the Russian Federation and Ukraine [1, 2, 4, 11].

Vertebroplastic bone cement has been employed in medicine over more than 50 years. It has found application not only in endoprosthetics for fixing components of an endoprosthesis to a bone, but also in other areas (plastic repair of vertebral bodies, stomatology, etc.). Bone cement fills the space between the endoprosthesis and the bone and forms an elastic zone intended both for functioning as a shock absorber and for uniformly distributing the load throughout the bone surrounding the endoprosthesis. The uniform redistribution of the load from the endoprosthesis to the bone is particularly important for the hip endoprosthesis stem, whose shape is generally imperfectly fitted to the shape of the femoral canal. This generates increased- and decreased-load zones (nonuniform distribution of forces).

Research areas in osteoporosis prosthetics (vertebroplasty) are the injective application and heterogeneity of bone cements. Bone cements are mainly produced manually or using a pulsating mixer. These technologies do not ensure the necessary product output rate; furthermore, they are insufficiently efficient from the economic standpoint. Russia's vertebroplasty is dominated by foreign brands of bone cement, which are well-promoted and avowed. The most demanded bone cements are acrylic ones, such as Vertebroplastic (De Puy Inc., Blackpool, England), DP-Pour (Den Plus Inc., Montreal, Canada), and Antibiotic Simplex (How Medical International Limited, London, England). Other popular options are calcium phosphate cements, namely, ChronOS Inject (Mathys Medical Ltd., Bettlach, Switzerland) and Biopex (Mitsubishi, Saitama, Japan).

The existing Russian brands of bone cement are in low demand, because they are less known and fall within the same price category, even though they are practically equal in their properties to their western analogues.

Preliminary studies demonstrated that the most promising apparatuses for preparing cement mixtures for vertebroplasty are continuous centrifugal mixers (CCMs). They ensure high-intensity mixing owing to the directed organization of the motion of thin, rarefied layers of the material (equal in size to the diameter of the particles being mixed). In addition, the centrifugal mixers reliably smooth the pulsations of the entering material flows. In continuous centrifugal apparatuses, it is possible to combine mixing and comminution processes. This feature provides means to obtain high-quality mixtures at large component-to-component ratios and is one of the basic advantages of the centrifugal technology.

The CCMs suggested here make it possible to produce bone cements that are equal in quality, if not superior, to the existing cements at lower expenses. This mixing method is technologically simpler than mixing in the pulsating apparatuses that are currently used in the preparation of cement mixtures.

Therefore, the problem of developing novel, high-performance CCMs for producing quality bone cements

is of high scientific and practical significance for public health care throughout the Russian Federation.

EXPERIMENTAL

In order to find a rational method of mixture preparation, we studied the flowability of cement components.

Granular materials are typically two-phase systems consisting of solid particles dispersed in air or in a gas medium.

The flowability of a material (Q) is a complex characteristic depending on many factors: density, particle-size distribution, particle shape, and particle surface conditions. The basic factors determining the flowability of powders are interparticle friction and cohesion (cohesive forces acting between particles), which counteract the motion of the particles relative to one another. Flowability is calculated via the formula:

$$Q = \frac{G_M}{S \cdot \tau}, \left[\frac{\text{kg}}{\text{m}^2 \cdot \text{s}} \right] \quad (1)$$

where m is the amount of material (kg), S is the outflow area (m^2), and τ is the material outflow time (s).

For estimating the effect of the flowability of cement components on the inertial forces in the flow of the materials being mixed, we will introduce the criterion of flowability Si :

$$Si = \frac{Q}{\rho \cdot d \cdot n}, \quad (2)$$

where ρ is the density of the material (kg/m^3), d is the average diameter of the cones (m), and n is the rotational frequency of the rotor (s^{-1}).

The flowability of cement components was measured using a setup that does not subject the granules to compression (Fig. 1). The setup has a hopper with a conical base. At the bottom of the hopper, there is a shutter plate, in a guiding slot, that can be moved to regulate the material outflow area S . The resulting mixture is collected in a receiving bin.

Experiments were performed in two modes. In the first mode, the material flew by gravity. In the second, the material was moved using a blade stirrer mounted inside the hopper. In both cases, the same amount of material (m) was placed in the hopper and the material outflow time τ at a fixed outflow area S was measured with a stop watch.

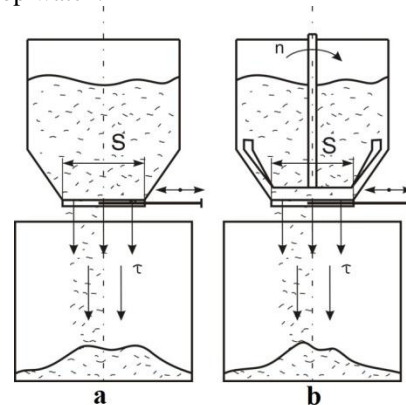

Fig. 1. Flowability determination setup (a) without a stirrer and (b) with a blade stirrer.

The experimental data of this study provide a basis for husing whether it is appropriate to use a CCM, whose advantage is that it yields a homogeneous mixture by crushing the conglomerates resulting from the introduction of a liquid phase into the granular material.

For obtaining bone cement, the Department of Food Production Engineering of the Kemerovo Institute of Food Science and Technology developed a mixing unit consisting of the new centrifugal mixer [3] and doser block.

The new CCM was used to prepare a pilot batch of bone cement consisting of polymethyl methacrylate (PMMC), a hydroxylapatite (HAP) bioactive calcium phosphate ceramic, and a tricalcium phosphate (TCP) ceramic, with PMMC : HAP : TCP = 90 : 5 : 5. The same experiments were performed using the base design of the mixer (Big Bill Orbital Bench Top Shaker, M49235, Barnstead International, Dubuque, Iowa).

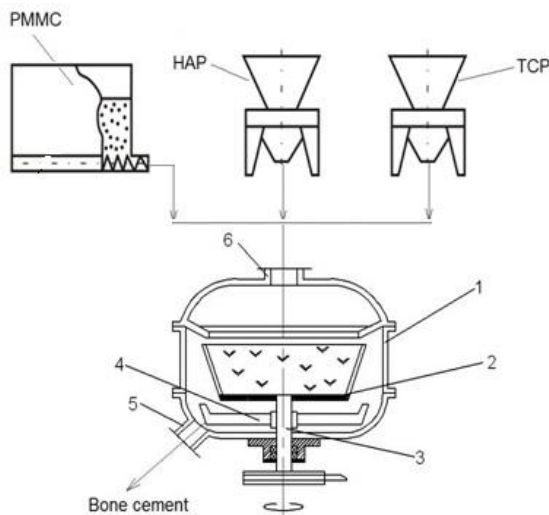

Fig. 2. Mixing unit: (1) mixer body, (2) disc, (3) shaft, (4) discharging blades, (5) outlet pipe, and (6) inlet pipe.

The centrifugal mixer (Fig. 2) operates in the following way. Granular materials, fed with volume dosers through inlet pipe 6, find themselves on the base of disc 2 of the rotating rotor and spread uniformly over the disc under the action of the centrifugal force. Next, the particles move upwards on the surface of a hollow, thin-walled, truncated cone, rounding elbow-shaped turbulizers and crossing past the latter. Thus, the particles being mixed are multiply separated and meet again and this improves the quality of the resulting mixture. The granular mass reaches the upper edge of the cone and is thrown out of the cone by the centrifugal force. The finished mixture falls onto the bottom of the apparatus and is brought out of the latter by discharging blades 4 through outlet pipe 5.

The organization of the straight and crossing material flows in this CCM makes the components flow pattern in the apparatus close to the perfect mixing model.

The particles of the components being mixed are under the action of both the centrifugal force and the drag force from air. As a consequence, they are

involved in swirling motion until they leave the apparatus. Mixing in the swirling flow is due to the deceleration of lower layers of the material upon their contact with the rotor surface and, subsequently, with the mixer walls. Since air has a certain viscosity, its layers that are adjacent to the inner surface of the rotating rotor are set in rotary motion by viscous friction forces. These layers experience the same forces as the mixture particles. The air drag sets the granular material in motion, forming turbulent dust–gas flows.

One of the most important characteristics of mixing efficiency is the heterogeneity coefficient of the key component of the mixture, V_c . It characterizes the uniformity of the distribution of the components in the mixture. We also determined the product output capacity of the apparatus and specific energy requirement, which are equally important process parameters. These data are presented in Table 3.

RESULTS AND DISCUSSION

The particle diameters and densities of the materials whose flowability was determined are listed in Table 1.

Table 1. Some properties of cement components

Cement component	Particle diameter, m	Particle density, kg/m ³
Polymethyl methacrylate	800×10^{-6}	1190
Hydroxylapatite bioactive calcium phosphate ceramic	300×10^{-8}	3156
Tricalcium phosphate ceramic	100×10^{-6}	3140

The flowability and criterion of flowability data calculated for the cement components via formulas (1) and (2) are listed in Tables 2 and 3.

Table 2. Flowability data for the cement components flowing by gravity

	Flowability Q , kg/(m ² s)		
	PMMC	HAP	TCP
	31.09512	40.67651	37.13355
Criterion of flowability S_i			
s-1	PMMC	HAP	TCP
9	0.014395889	0.01956542	0.01833756
11	0.011778455	0.01600807	0.01500345
13	0.009966385	0.01354529	0.01269523
15	0.008637533	0.01173925	0.01100253
17	0.007621353	0.01035816	0.00970812
20	0.00647815	0.00880444	0.0082519

The materials subjected to mechanical stirring show a higher flowability (Tables 2, 3). Note also that the physicochemical properties of the materials are similar and have no significant effect on their flowability, which remains invariable throughout the outflow area range.

These experiments were followed by determination of the flowability of a pilot batch of bone cement consisting of polymethyl methacrylate, a hydroxylapatite bioactive calcium phosphate ceramic,

and a tricalcium phosphate ceramic. The mixture begins its motion at a 2/3 open outflow area ($S = 0.001024 \text{ m}^2$), and its flowability remains the same when the shutter is fully open. This is due to the fact that PMMC, which has strong adhesive properties, causes particle arching in the conical part of the hopper, thus hampering the mutual motion of the other particles of the mixture and slowing down their flow. Therefore, the materials considered here can be assigned to poorly flowing ones.

Table 3. Flowability data for the cement components moved by the blade stirrer

Flowability Q , kg/(m ² s)			
	PMMC	HAP	TCP
	32.093	43.10864	38.10774
Criterion of flowability Si			
s ⁻¹	PMMC	HAP	TCP
9	0.01485787	0.02073528	0.01881864
11	0.012156439	0.01696523	0.01539707
13	0.010286218	0.01435519	0.01302829
15	0.008914722	0.01244117	0.01129118
17	0.007865931	0.0109775	0.00996281
20	0.006686042	0.00933087	0.00846839

Experiments demonstrated that the flowability of the materials depends markedly on their particle size distribution and density. Using the Statistica 6.0 program package, we estimated the functional relationship between the independent variables d and ρ and the response Q , by the multiple regression method.

Table 4 presents the goodness-of-fit parameters of this regression analysis. For example, the coefficient of determination for PMMC is $R^2 = 0.99$, indicating that the results of the regression analysis account for more than 99% of the scatter of the variables around the mean value. The regression model obtained by this analysis is highly significant, since the significance level p for the materials is close to zero.

Table 4. Regression analysis data

Regression parameters	PMMC	HAP	TCP
Multiple R	0.99	0.99	1
Multiple R^2	0.99	0.99	1
Corrected R^2	0.98	0.99	0.99
Fisher test F	86.93	529.5	1892
Significance level p	0.075	0.03	0.016
Standard error of estimation	7.937	5.12	2.045

In order to see which independent variable (d or ρ) is the most significant factor in the flowability of the materials, it is necessary to examine the standardized regression coefficients $Beta$ and unstandardized regression coefficients B listed in Table 5.

As is clear from Table 5, the most significant factor in the flowability of a material is its density: the weighting factors of density are large compared to those of particle diameter. Some of the $Beta$ values for d are

negative, indicating that the flowability of the granular material decreases with an increasing particle diameter.

Table 5. Multiple regression data

Polymethylmethacrylate					
	$Beta$	Standard error	B	Standard error	p -Level
Free term			-2320	4555	0.7
d	0.25	1.95	177.6	1374	0.92
ρ	1.24	1.95	1.78	2.78	0.63
Hydroxylapatite ceramic					
Free term			-2943	2654	0.46
d	-0.07	0.679	-390	3784	0.93
ρ	0.92	0.68	2.1	1.53	0.4
Tricalcium phosphate ceramic					
Free term			1167	1451	0.56
d	-1.15	0.53	-6486	3020	0.27
ρ	-0.15	0.53	-0.26	0.914	0.82

Processing the experimental data yielded the following empirical relationship for determining the flowability of the mixture as a function of particle density and diameter:

$$Q = 4910 + 2214d + 6\rho + 816d^2 - 2d\rho - 0.0017\rho^2; R^2=0.957 \quad (3)$$

Dimensionless equation (3) is valid only for the granular materials considered here, with particle diameters of 0.003 to 0.8 mm and densities of 1200 to 3160 kg/m³.

For elucidating the behavior of the bone cement components under the action of the inertial forces, we analyzed the motion of their particles on the rotor of the centrifugal mixer (Fig. 2) at a rotational frequency of $n = 9-20 \text{ s}^{-1}$. The results obtained are presented in Tables 2 and 3, from which it is clear that the criterion of flowability Si decreases with an increasing rotational frequency of the rotor. The largest Si values were obtained for the hydroxylapatite ceramic at the lowest rotational frequency of the rotor; however, because of the high density of this material, these values are close to the values observed for poorly flowing materials ($Si = 0.02$).

To set up a dimensionless equation describing the mixing of granular materials, it is necessary to calculate the criterion of power K_N using the formula

$$K_N = \frac{N}{\rho \cdot n^3 \cdot d_k^5}, \quad (4)$$

where N is the useful power spent on the mixing of the granular materials (W), ρ is the density of the particles of the material (kg/m³), d_k is the mean diameter of the conical rotor on which the particles move (m), and n is the rotational frequency of the rotor (s⁻¹).

The calculated criterion of power data demonstrate that K_N increases as the diameter and rotational frequency of the conical rotor are increased. This is due to the fact that the holdup capacity of the mixer grows with an increasing cone diameter. The K_N values for the mixture components fall in the range from 4 to 16, which is characteristic of poorly flowing materials (for

readily flowing ones, $K_N = 0.05\text{--}0.5$). This is explained by the fact that poorly flowing materials, possessing adhesive properties, hamper the motion of the particles relative to one another and on the cone surface. As a consequence, the flowability of the material decreases. This leads to a buildup of the material on the rotor and, accordingly, to an increase in the power required for mixing.

Figure 3, plots the criterion of power versus the criterion of flowability at $n = 9\text{--}20\text{ s}^{-1}$ and $d_k = 0.4\text{ m}$ for the main component of bone cements – polymethyl methacrylate.

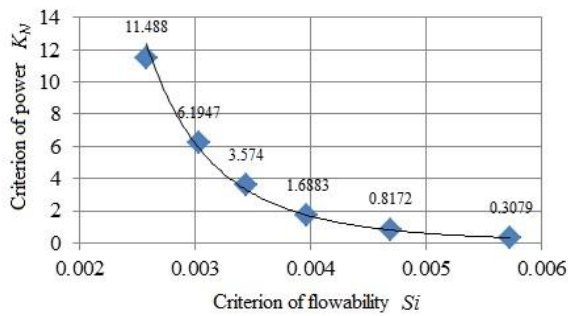

Fig. 3. Criterion of power K_N versus criterion of flowability S_i .

It is clear from Fig. 3 that the criterion of power and, accordingly, the power consumed decrease dramatically with an increasing criterion of flowability. Note here that K_N depends more strongly on the interparticle and particle–rotor surface friction than on the inertial forces. Between 0.004 and 0.006, K_N is practically independent of the criterion of flowability. In this K_N range, the energy requirement depends only on the inertial forces, which far exceed the interparticle and particle–inner rotor surface friction forces.

Experimental data processing using the EXCEL program yielded the following dimensionless equation for the mixing of granular materials:

$$K_N = 2 \cdot 10^{-11} \cdot S_i^{-4.5}, \quad (5)$$

Dimensionless equation (5) is valid only for granular materials with particle diameters of 0.003 to 0.8 mm. Equation (5) is convenient for approximate engineering and economic calculations; however, it is necessary to take into account that this equation leads to a large error of $\pm 30\%$. In more accurate calculations, it is necessary

to use dimensionless relationships established for each particular component of the mixture.

In view of the aforesaid, it can be hypothesized that the centrifugal mixer is the most appropriate means of preparing bone cements. Since the centrifugal forces exert an intense action on the material being mixed, the poorly flowing components undergo uniform mixing without forming agglomerates.

In order to verify this hypothesis, we determined the quality of the mixtures obtained with the new CCM and with the base mixer at a fixed product output rate. The rotational frequency of the rotor in these experiments was $n = 12.5\text{ s}^{-1}$. The performance of these mixers was characterized in terms of specific energy requirement. The results of the experimental tests of the two mixers are presented in Table 6.

Table 6. Testing data for the two mixers

Mixer	Product output rate	Specific energy requirement	V_c
	kg/h	kW h/m ³	%
New CCM	200	0.66	4.21
Base design	200	1.28	7.03

An analysis of these data demonstrates that, for obtaining quality bone cements, it is pertinent to employ the new CCM for the reason that, other conditions being equal, it affords better mixtures at a lower energy input than the base apparatus.

CONCLUSIONS

The criterion of flowability introduced in this study provides means to find the most rational mixing technology, to predict the behavior of the mixture during the process, and to more precisely tune the proportions of the components to be mixed.

A dimensionless equation accurate to 6% has been set up for determining the energy requirement for the mixing of the granular materials considered in the article.

As compared to the base apparatus, the new CCM as an element of the processing line in the manufacturing of bone cements would afford a higher product output rate at a low steel and energy intensity. This would make it possible to manufacture, at a lower cost, quality bone cements capable of meeting competition with their foreign analogues.

REFERENCES

1. Valiev, A.K., Dolgushin, B.I., Aliev, M.L., et al., *Materialy III s'ezda onkologov i radiologov SNG* (Proceedings of the III Congress of Oncologists and Radiologists of the Commonwealth of Independent States), Minsk, 2004, p. 255.
2. Dzindzhikhadze, R.S., Lazarev, V.A., et al., *Neirokhirurgiya (Neurosurgery)*, 2005, no. 1, pp. 36–40.
3. Borodulin, D.M., Andryushkov, A.A., and Voitikova, L.A., RF Patent 2496561, *Byulleten' izobretenii (Inventions bulletin)*, 2013, no. 19.
4. Pedachenko, E.G. and Kushchev, S.V., *Ukrainskii meditsinskii chasopis (Ukrainian medical journal)*, 2006, no.6, pp. 96–101.
5. Do, H.M., Kim, B.S., Marcellus, M.L., et al., *American Journal of Neuroradiology*, 2005, vol. 26, pp. 1623–1628.
6. Irani, F.G., Morales, J.P., Sabharwal, T., et al., *British Journal of Radiology*, 2005, vol. 78, pp. 261–264.
7. Jensen, M.E., McGraw, J.K., et al., *Journal of Vascular and Interventional Radiology*, 2007, vol. 18, pp. 325–330.
8. Lips, P., *American Journal of Medicine*, 1997, vol. 103, no. 2, pp. S3–S11.
9. McGraw, J.K., Gardella, J., Barr, J.D., et al., *Journal of Vascular and Interventional Radiology*, 2003, vol. 14, pp. 827–831.
10. Rigg, B.L. and Melton, L.J., *Bone*, 1995, vol. 17, no. 5, pp. 505–511.
11. Stallmeyer Bernadette, M.J., Zoarski, G.H., and Obuchowski, A.M., *Journal of Vascular and Interventional Radiology*, 2003, vol. 14, no. 6, pp. 683–696.